

Solar All in One SE Street Light

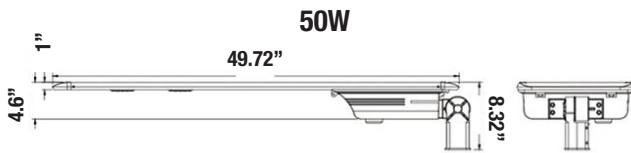

Angle of Light Source: -60° / +60°

Bird Spikes



50W

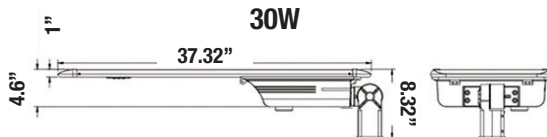
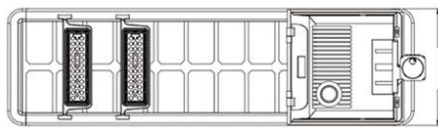

30W

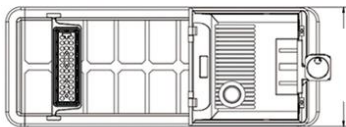

Mounting Options

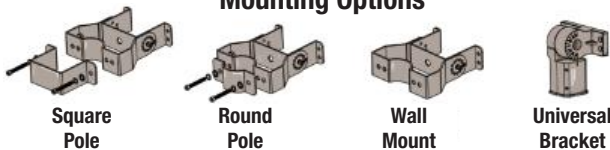

Square Pole

Round Pole

Wall Mount

Universal Bracket

Outdoor solar lighting system uses solar cells which convert sunlight into electricity. Electricity is stored in the battery for use at night. SE Solar LED Street Light features all in one design function, low profile design with PIR/microwave motion sensor and smart controller all built in with bifacial solar panel. SE Series Solar Lights are easy to install and virtually maintenance free.

- Economical, easy to install, all in one integrated with bifacial solar panel on top and bottom for faster charging time.
- Philips LumiLEDs luxeon 5050 chip creates a first class light source 200 lumen per watt, with the aluminum lamp base and sealed lens with its excellent heat dissipation.
- The sealed lenses are made of strong UV protected PC and are aging and shock resistant.
- The light automatically switches on at dusk and switches off at dawn. 50% permanent lighting, when motion is detected power turns to 100%.
- Deep cycle battery, charge and discharge over 2000 times, continuously works 2-3 rainy days in intelligent mode.
- MPPT controller automatically track the maximum power point according to the weather variation, charging rate 30%.
- 200 Lumen per watt and IP65
- 3 Years warranty on all components
- Optional Accessory : Intelligent App Control, IOT Management system, Camera, Bird Spikes
- Bracket Option: Universal Slip Fitter (2 3/8"), for Wall Mount, for Round Pole and for Square Pole



Solar All in One SE Street Light

Specifications

Model #	SKU #	Power	PV Type	Solar Panel	Lumens	Lithium Battery	Charge Time (Hrs)	Material	IP Rating	Installation Height (Ft)
AVS-Ai1sE-30W	786107	30W	MONO	50W / 18V	6091	307.2W 12.8V	6.14	ALUMINUM	IP65	16.4-26.2
AVS-Ai1sE-50W	786108	50W	MONO	70W / 18V	10091	460.8W 12.8V	6.58	ALUMINUM	IP65	19.7-32.8

- Operating time: 15 hours full power, intelligent mode 5-7 days.
- Input Voltage: 12-24V constant voltage.
- Control Mode: Light Control + Motion Sensor/Time Control/PIR Built In.
- Working Mode: 30% of intensity at first 4 hrs, 100% bright when people or car pass by, then rest of time 30% of intensity, and 70% of intensity when people pass by.
- Housing: Die-Casting Aluminum, Anti-Corrosion.
- Life Hours: >50,000 hours.

OPTIONAL ACCESORIES

- 4KV (Surge Protector)
- Intelligent APP control
- IOT Management
- AC & DC complementary
- USB power
- Alarm
- Security camera

AUTOMATIC INTENSITY ADJUSTMENT

MOTION SENSOR IS SENSITIVE UP TO 29.5 FT

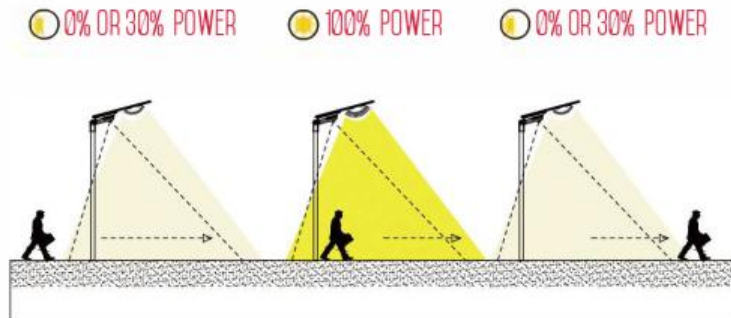

High Efficacy Lighting
60W Replace 400W Traditional Model



Smart Lighting Control
IOT Remote Monitoring Analysis

Wattage	Lumens (+/-5%)	Efficacy	Solar Panel	Battery			Optical Lens	IP&IK Rating	Installation Height	Fixture Dimension	Carton Dimension
				Voltage	Wattage	Charging Time					
30w	6091lm	203lm/w	50w/18v	12.8v	307.2w	6.14 hrs	75*160°	IP65	16.4 TO 26.2 FT	L948*W365*H211.4mm L37.32*W14.37*H8.32Inch	L1140*W190*H435mm L44.88*W7.48*H17.13Inch
50w	10091lm	203lm/w	70w/18v	12.8v	460.8w	6.58 hrs	Type 3	IP65	19.7 TO 32.8 FT	L1263*W365*H211.4mm L49.72*W14.37*H8.32Inch	L1455*W190*H435mm L57.28*W7.48*H17.13Inch



Solar All in One SE Street Light

Correlated Color Temperature

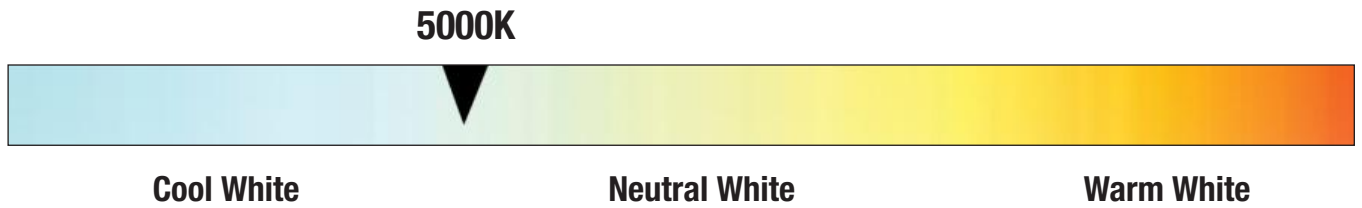

Dimensions

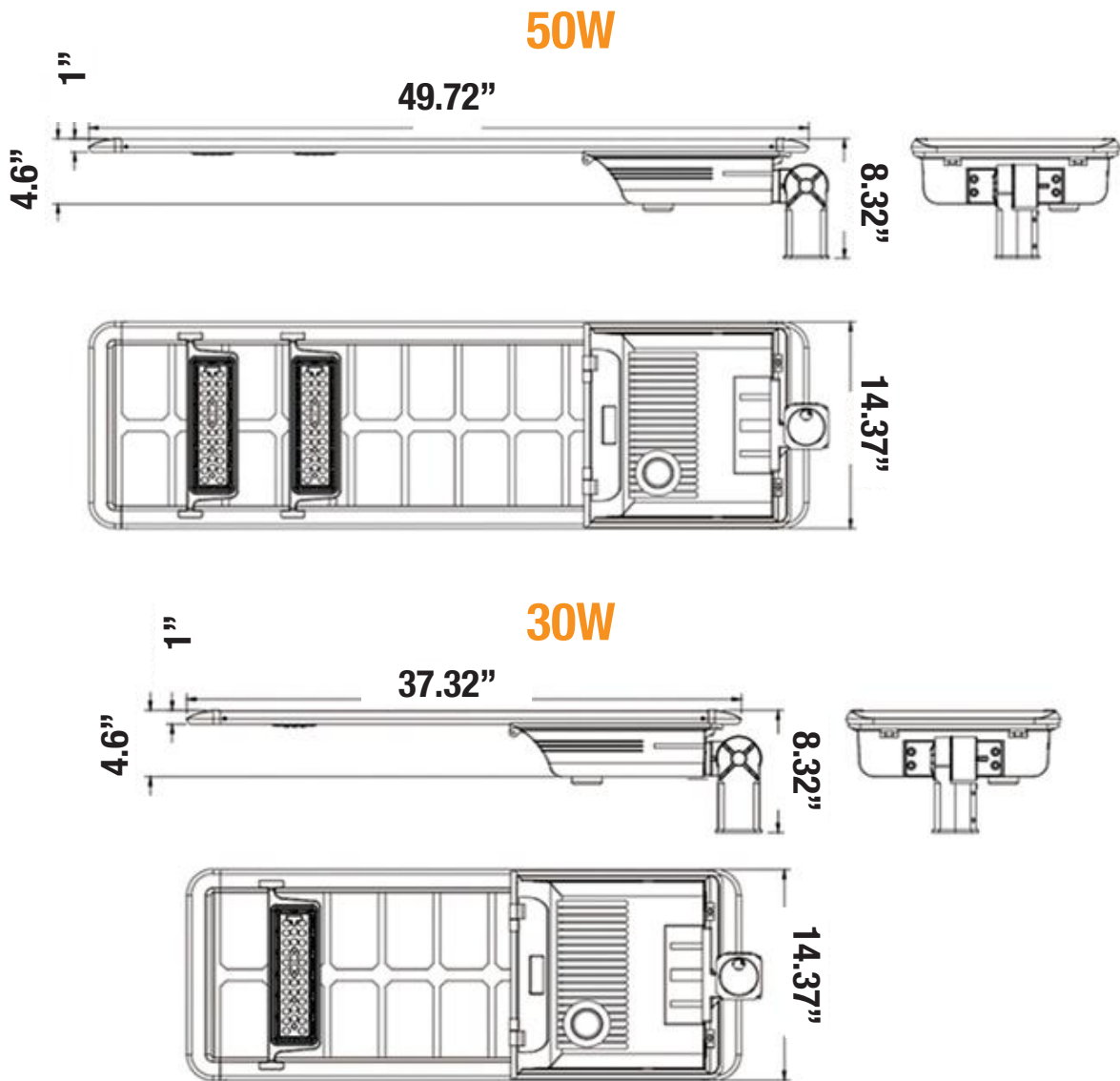

Solar All in One SE Street Light

Dimensions

Mounting Options

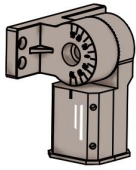

Universal
Bracket

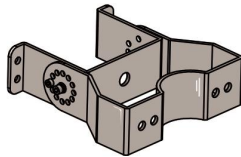

Wall
Mount

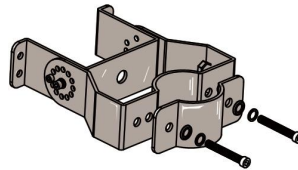

Round
Pole

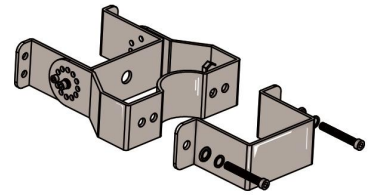

Square
Pole

Universal Bracket - Slip Fitter - Type A

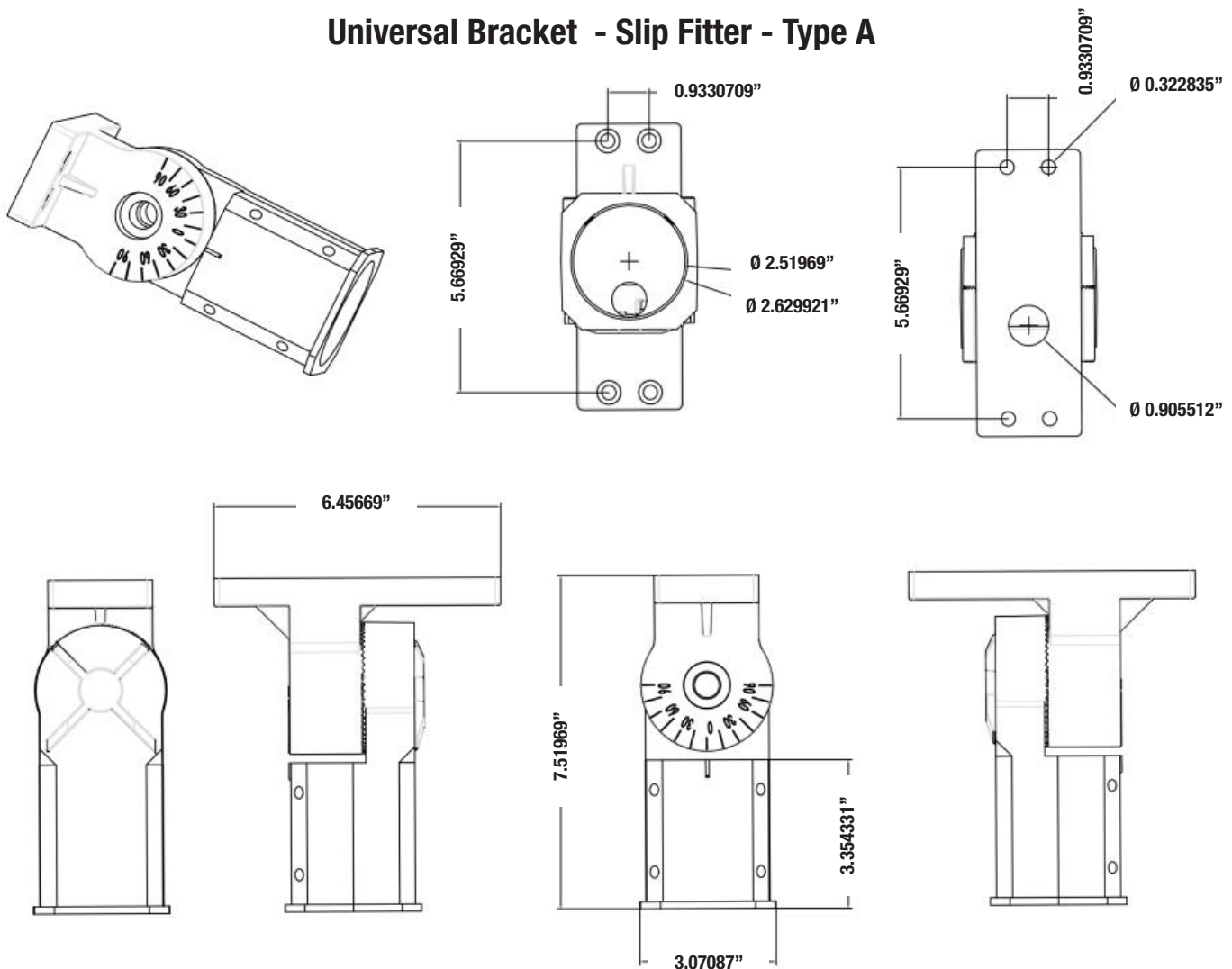

Solar All in One SE Street Light

Dimensions

Wall Mount - Type B-1

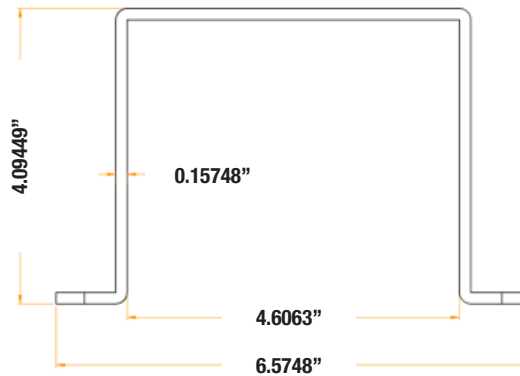
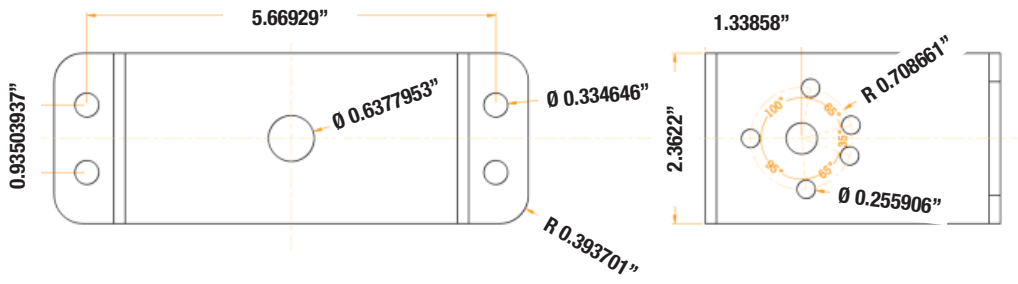
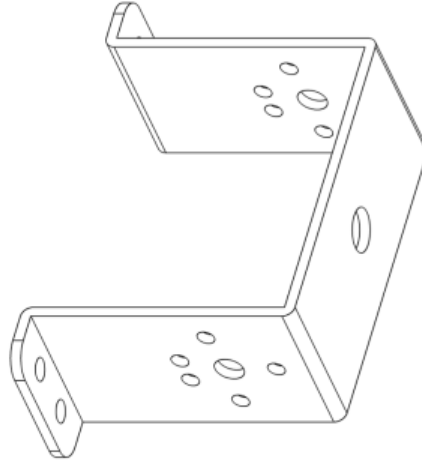

Solar All in One SE Street Light

Dimensions

Wall Mount - Type B-2

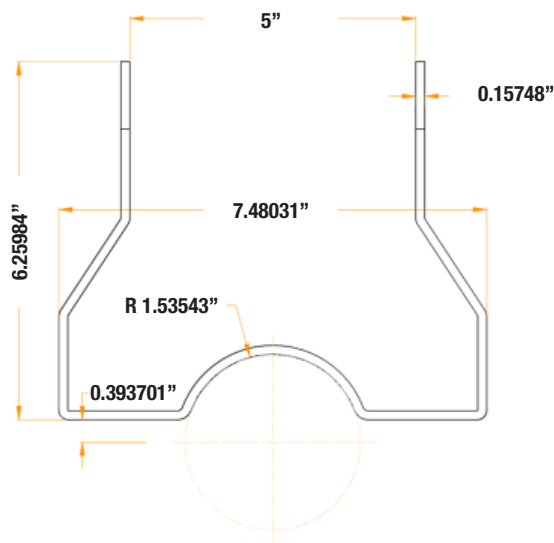
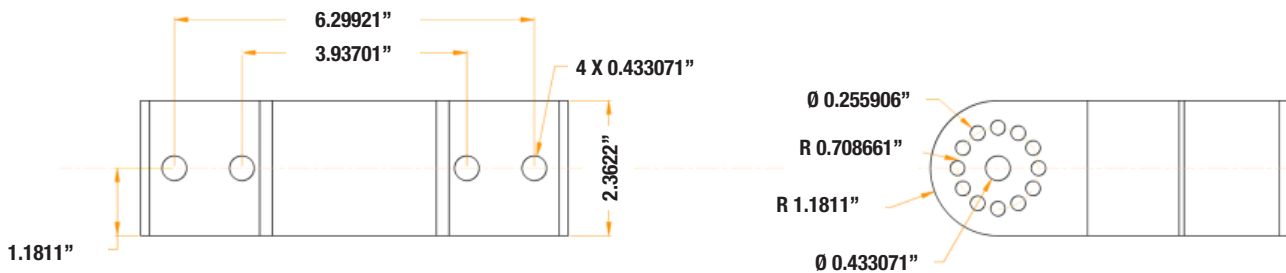
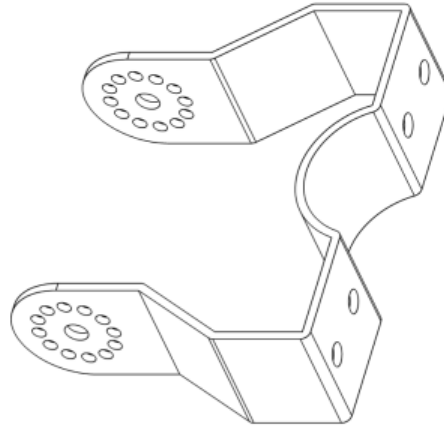

Solar All in One SE Street Light

Dimensions

Round Pole - Type C

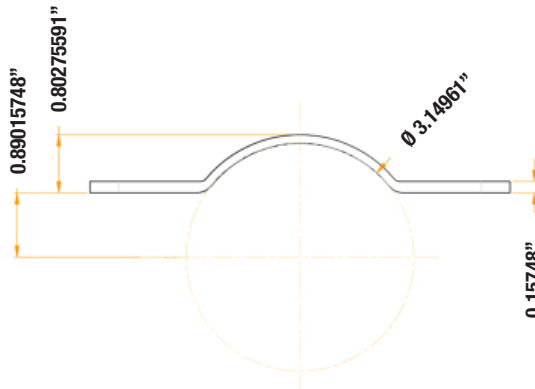
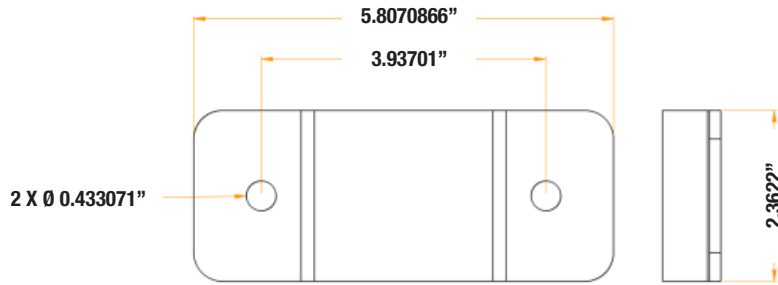

Solar All in One SE Street Light

Dimensions

Square Pole - Type D

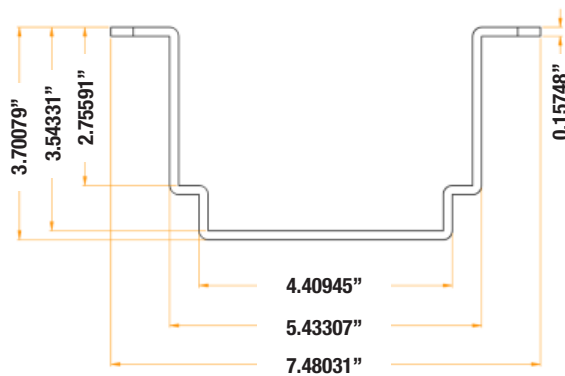
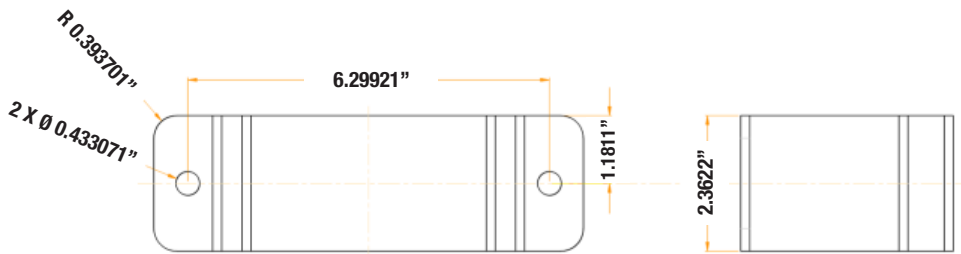
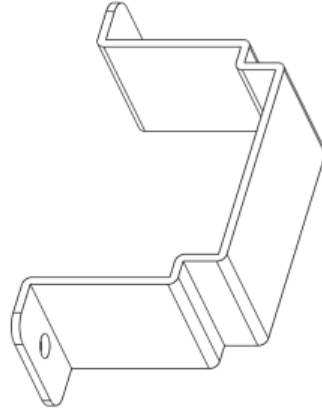

Solar All in One SE Street Light

Product Design and Benefits

- **SE solar LED street light** features all in one design function, low profile design, with PIR/microwave motion sensor and smart controller all built in.
- **Bifacial Solar Panel** design. Suitable for remote region, non electricity supply zone.
- Deep cycle battery, charge and discharge over **2000 times**.
- Continuously **work 5-7 rainy days in intelligent mode**.

FEATURES

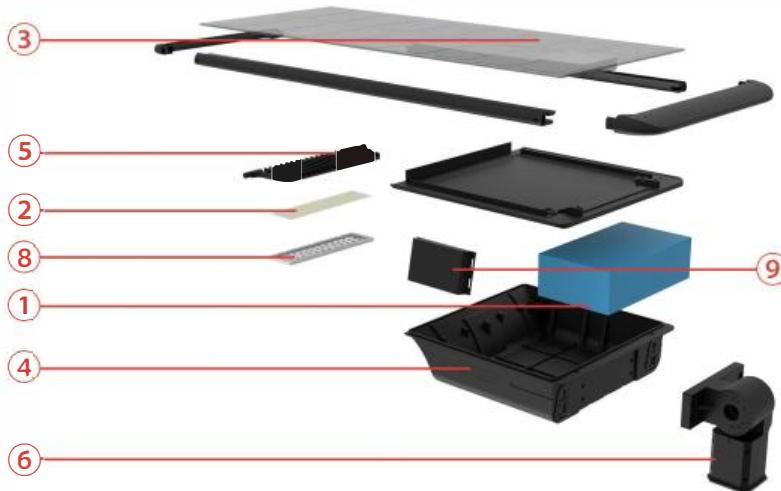

INTEGRAL
MONOCRYSTALLINE
SILICON SOLAR PANEL



CONVERSION RATE
UP TO 30%



25 YEARS
LIFESPAN

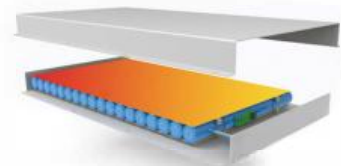

LIFESPAN CYCLE MORE THAN 2000 TIMES
INTELLIGENT TEMPERATURE CONTROL

- Easy battery replacement design, can be renewed for 7 years.
- ② Ultra-high light efficiency, 10 watts equivalent to 20 watts of others at least.
- ③ Bifacial solar panels, the overall conversion efficiency is increased by 30%.
- ④ Unique anti-theft technology on battery door.
- ⑤ Rotatable LED module, worry-free installation, best solar panel angle adapt to the sun.
- ⑥ The various installation methods suit for any application likes light poles, wall surface and etc.
- ⑦ From 10 to 60 watts, can replace the traditional 35-240 watts, meeting all road application conditions.
- ⑧ More than 30 different optical road lighting designs, adapt to various road conditions but no waste of light.
- ⑨ PIR/microwave motion sensor and smart controller all built in. AC and DC complementary, also USB power and alarm supply when emergency use.

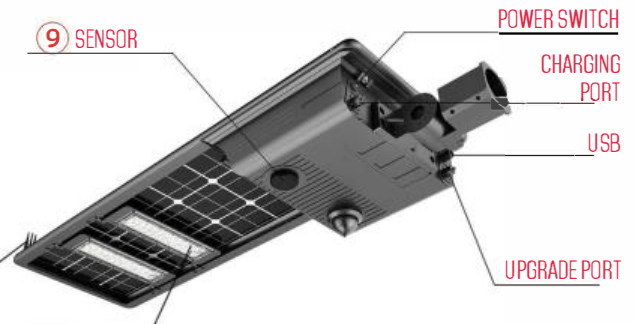
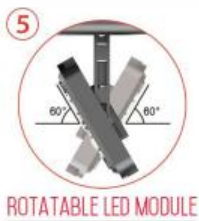

Solar All in One SE Street Light

Product Design and Benefits

LED CHIP



LUXEON 5050

Philips Lumileds Luxeon 5050 chip creates a first-class light source

By choosing the luxeon LED chips, single lumen value at 240lm/w, with the aluminum lamp base and sealed lens, with its excellent heat dissipation, it is as if the LED chip has been placed in a sealed unit. Thus it maintains high brightness levels with very little fading. The sealed lenses are made of strong UV protected PC and are aging and shock resistant; The well optimized light distribution, makes for a more uniform and wider lighting area.

HIGH-LUMEN EFFICACY LED MODULE

Lumen efficiency > 220lm/w, achieve higher illumination



Angle of Light Source: -60°/+60°



High luminous efficiency Long lifespan Less heat Low light decay

OPERATION

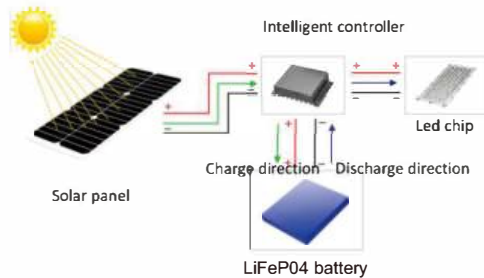

Where there is light radiation, photovoltaic modules are converted to electric energy by solar radiation, and intelligent controller is used to charge electric energy into lithium iron phosphate battery. At the same time, the intelligent controller protects the overcharge and over discharge of the battery. The lighting switch and adjust lighting intelligent control, without manual operation.

PHOTOMETRICS

Planning and analyzing of street lights can be done by using lighting design software, which allows lighting simulations. It uses rendering, the process of generating an image from a model, by means of computer programs resulting in different tools for measuring the simulated light levels.

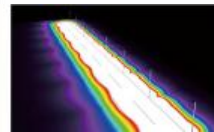

Example of urban branch road

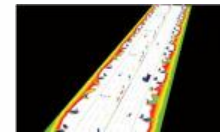

Example of main road and parking lot

MOBILE BLUETOOTH APP

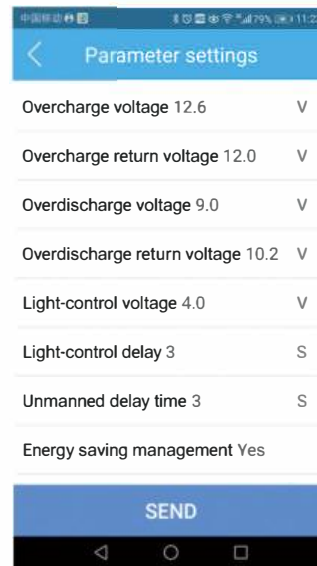

Multiple lighting modes can be programmed remotely by Mobile Bluetooth APP Solar Street light with inbuilt Bluetooth for health monitoring with APP



Solar All in One SE Street Light

Product Design and Benefits

SMART LIGHTING CONTROL SYSTEM

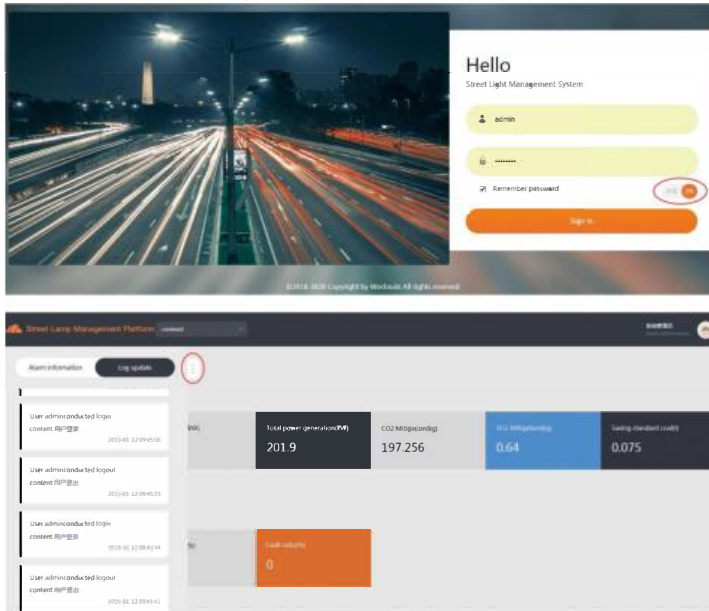

DATA & PROJECT MANAGEMENT

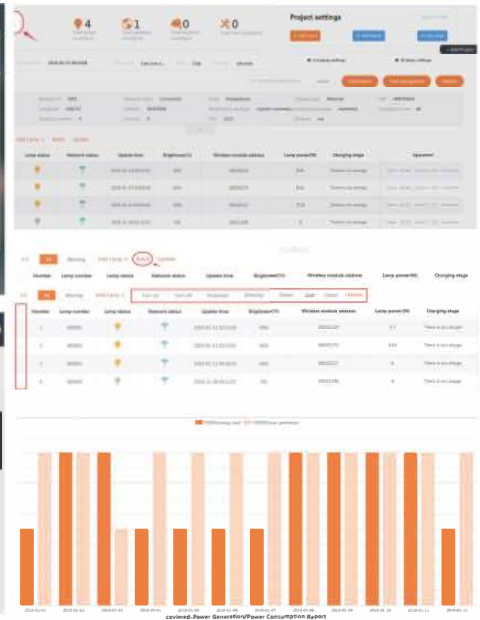

The system can pre-set one or more lighting modes according to different time of day and traffic flow, automatically turn on or off any lamp, and adjust the switching time and illumination according to environmental requirements to achieve the purpose of energy saving and consumption reduction.

IOT MANAGEMENT & INTELLIGENT LIGHTING

We perfectly combine traditional solar street lighting architecture+Internet of things + wireless communication technology perfectly, achieve monitoring and management of remote background data, real-time understand the normal working status of each component of solar energy (street lights, photovoltaic panels, batteries, controllers), allow you to know the end customer's product usage that is thousands of miles away without leaving home, or to manage the opening and closing of street lights and the adjustment of bright spot power in a timely manner.



Remote monitoring real time monitoring

SE series with wireless communication function, Through the intelligent management system of solar street lamp and wireless module, have remote monitoring and real-time monitoring.



Automatic fault alarm

Real time monitoring of solar panel voltage, current, power, battery charging and discharging current, voltage, load working state, controller working state data and fault automatic alarm.



Remote control

Support remote switch on and off dimmer and battery, load parameter modification.



Fault tracking and precise positioning

Multi peak PWM technology, suitable for partial shading or partial damage of photovoltaic cells, and the tracking efficiency is more than 99%.



Map location

Using GIS maps, with geographic display capabilities.



Solar All in One SE Street Light

Product Design and Benefits

The Internet of Things solar street light management system is mainly composed of a street light component+a centralized controller+a single light controller+a smart cloud platform. The centralized controller and the single light controller aggregate the data collected by the single light via the GPRS/NB-IOT wireless communication network. The centralized controller uploads data to the system cloud platform through GPRS data flow, providing data dependence for mobile phone and computer terminal access.

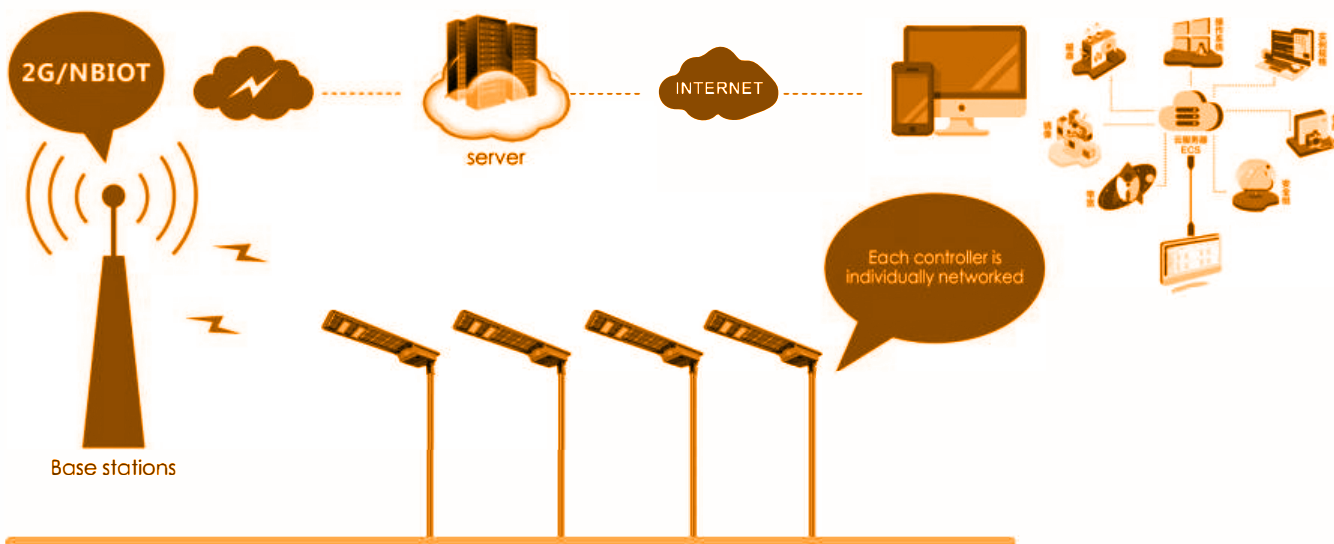

PERFORMANCE COMPARISON BETWEEN SMART IOT SOLAR LED STREET LIGHTS AND TRADITIONAL STREET LIGHTS

Solar led street light controller type	PWM+IOT controller	Instruction
Light decay detecting	✓	Automatic light decay detection and adjustment
Charging in rainy days	✓	PWM charge 3 rainy days is equivalent to a sunny day
Battery management	✓	Battery lifespan management
Remote monitoring	✓	Remotely monitor the status of each street light in real time
Optimize configuration	✓	Through data analysis, complete the optimal configuration of solar panels and batteries in different regions
Fault alarm	✓	Automatically detect system failures and alert to mobile phones or computers
Intelligent analysis	✓	Automatically collect the detailed data for per light at per night, and statistical report analysis
Artificial intelligence	✓	Big data collection and analysis through the system platform, complete the intelligent operation of street light and achieve stable lighting throughout the year



Solar All in One SE Street Light

Light Distribution

The Solar All in One SE Street Light is a Type 3 light for car parks and more.

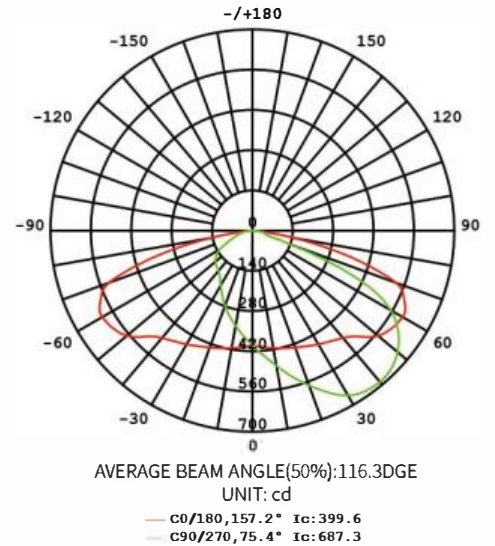
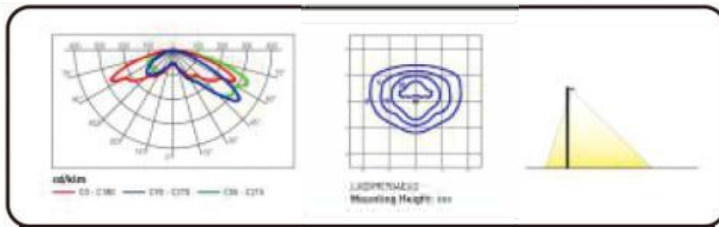

50W

Flux out: 9549 lm

Height	Eavg, Emax	Angle: 160.00deg	Diameter
1m	94.51, 2639.52lx		1134.26cm
2m	23.61, 659.80lx		2268.51cm
3m	10.50, 293.25lx		3402.77cm
4m	5.91, 165.00lx		4537.03cm
5m	3.79, 105.58lx		5671.28cm
6m	2.62, 73.32lx		6805.54cm
7m	1.98, 53.91lx		7939.79cm
8m	1.51, 41.22lx		9074.05cm
9m	0.95, 32.63lx		10208.31cm
10m	0.97, 26.39lx		11342.56cm

Note: The Curves indicate the illuminated area and the average illumination when the luminaire is at different distance.

30W

Flux out: 5981 lm

Height	Eavg, Emax	Angle: 160.00deg	Diameter
1m	59.20, 1653.26lx		1134.26cm
2m	14.79, 413.27lx		2268.51cm
3m	6.58, 183.68lx		3402.77cm
4m	3.70, 103.35lx		4537.03cm
5m	2.38, 66.13lx		5671.28cm
6m	1.64, 45.93lx		6805.54cm
7m	1.24, 33.77lx		7939.79cm
8m	0.94, 25.82lx		9074.05cm
9m	0.75, 20.44lx		10208.31cm
10m	0.61, 16.53lx		11342.56cm

Note: The Curves indicate the illuminated area and the average illumination when the luminaire is at different distance.



Solar All in One SE Street Light

Installation

This procedure is designed as an installation aid. Skilled tradespeople that are familiar with general construction and electrical installation techniques should perform the installation. Licensed electricians should provide electrical installation connections. Installations and connections should be done in accordance with all national and local codes and permits. In no way is this document intended to construe warranty or fitness of use of the products described, nor is it intended to provide safety instruction for those installing the product.

⚡ WARNING

Before proceeding with installation or service maintenance of this product:

- Disconnect power to reduce electrical shock risk.
- Review the entire Installation Guide.
- Inspect this properly packaged product for any damage that may have occurred during transit.
- Verify product application complies with manufacturer design recommendations.
- Verify the availability of necessary tools and incidental material.
- Verify applicable code requirements. Field assembly and installation are subject to acceptance by local inspection authority.
- Appropriate safety equipment to be determined by end user, per applicable safety standards and precautions.

INSTRUCTIONS

Step 1

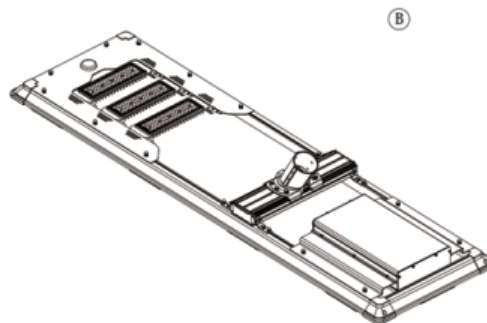
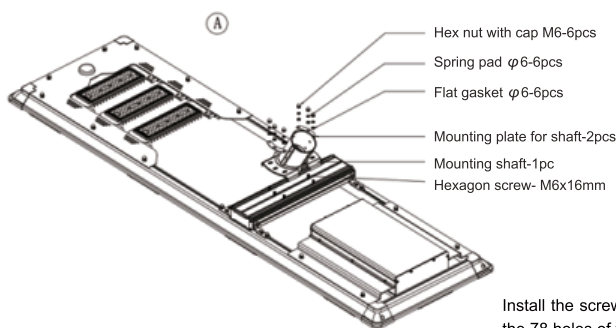

Install the screw on the profile (fixed in the middle) in alignment with the 78 holes of the mounting shaft, then use the corresponding screw on the mounting plate for shaft, and finally use the flat gasket and spring pad to install (as shown in Figure B)

Step 2

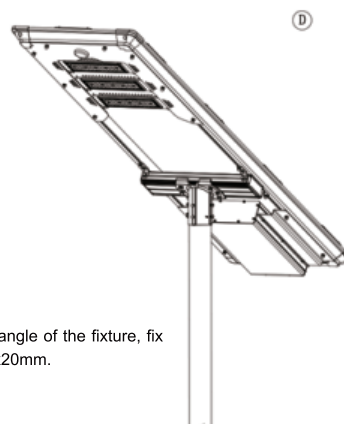
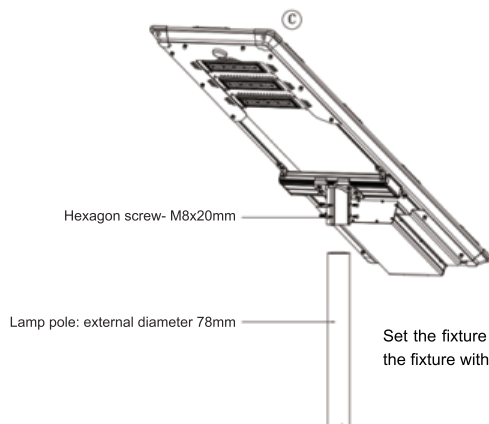

Set the fixture on the pole, adjust the angle of the fixture, fix the fixture with the hexagon screw M8x20mm.



Solar All in One SE Street Light

Optimum Panel Orientation

The Solar charge in a battery pack won't last forever. The off-grid system relies on stored solar energy for autonomy. Angling your solar panels properly can boost the power intake of your solar lighting system. You want to angle your solar panels at a tilt based on the area's latitude.

Tip for Maximum Power

You can increase the tilt 15° in the winter or decrease 15° in the summer. In this way you can get the maximum sunlight to recharge the battery.

Best Facing Direction of Solar Panel

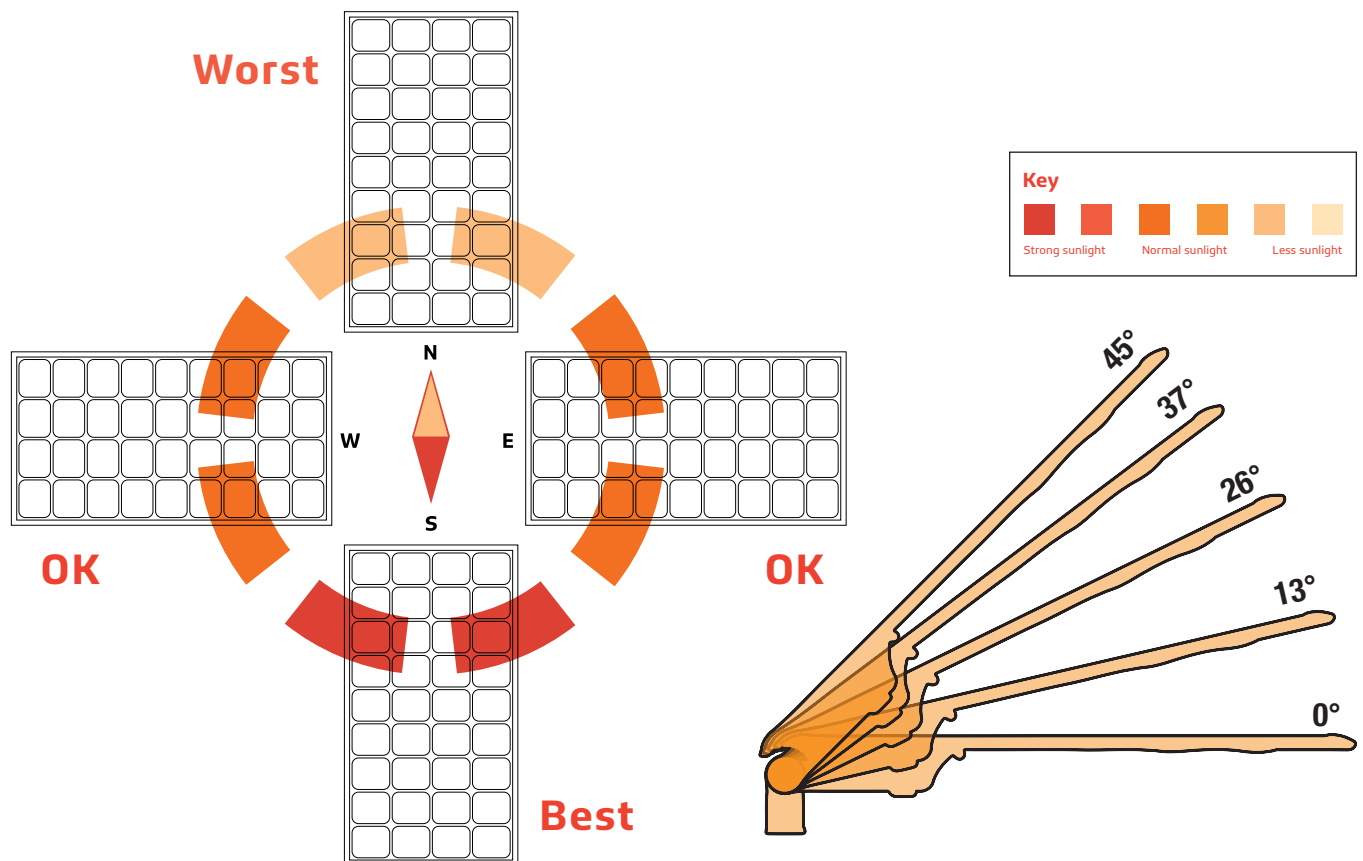

The area will dictate the installation of the fixtures and will sometimes prevent the lights from facing south. Panels facing West & East won't get as much light as Southern facing panels, but will still collect a good amount of sunlight. A North facing panel also works, but it will take longer to charge than any other direction. This would mean that the solar charge will be less optimal if installations are facing North.



Solar All in One SE Street Light

Optimum Panel Orientation

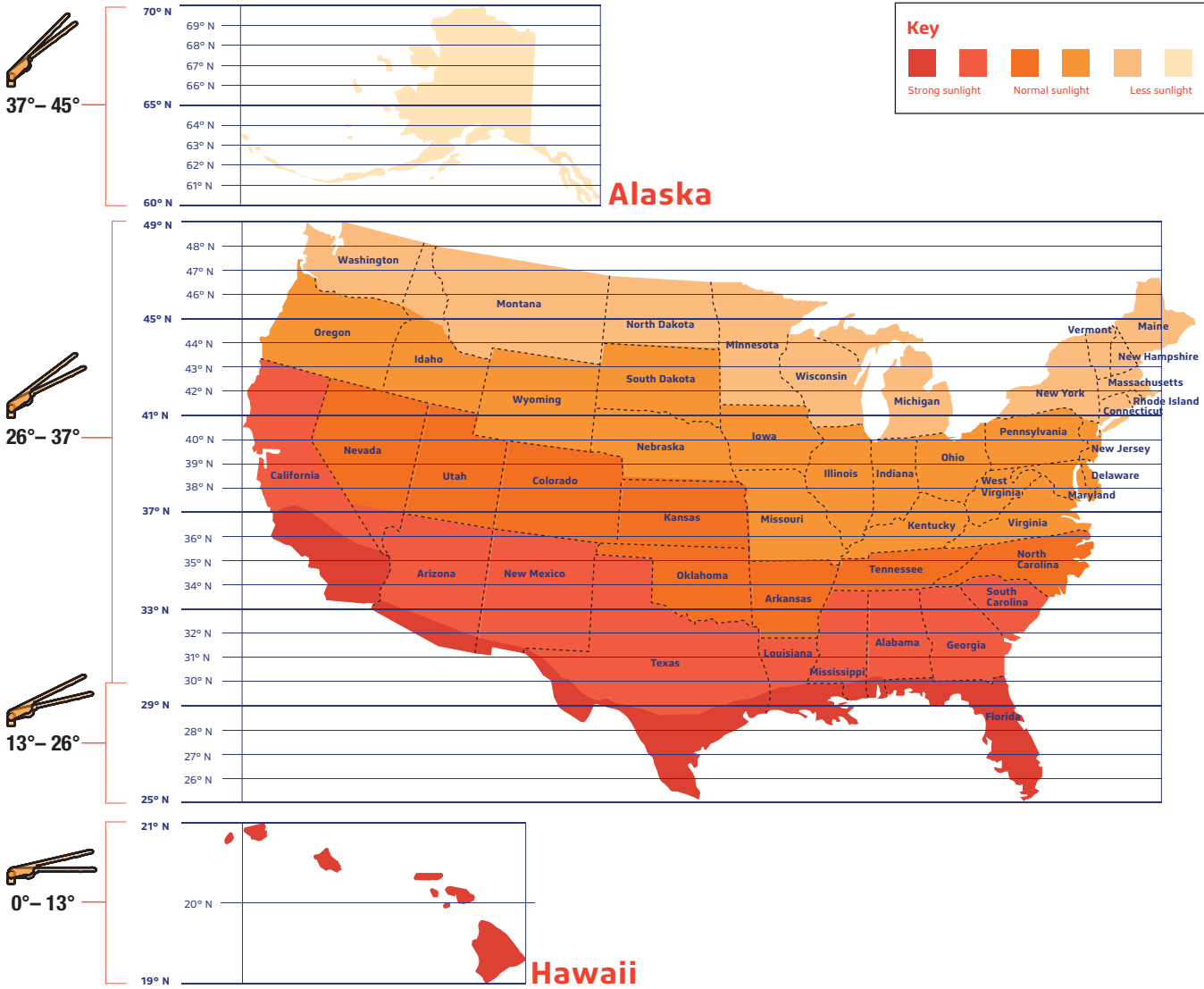

SOLAR AREA LIGHTS

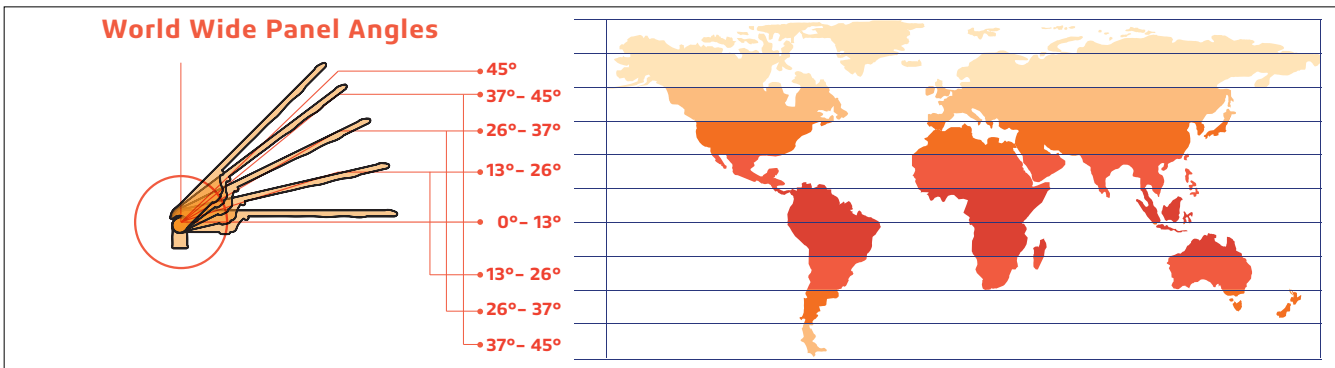

Solar All in One SE Street Light

Packaging

Model #	SKU #	Power	Pcs/Box	Box Dimensions (IN)
AVS-Ai1sE-30W	786107	30W	1	45 X 8 X 18 "
AVS-Ai1sE-50W	786108	50W	1	58 X 8 X 18 "

SOLAR AREA LIGHTS

Solar All in One SE Street Light

UP TO 220 LM/W

- SUPPORT 12HOURS UNDER 5-7 RAINY DAYS
- POWER: 30W & 50W



Bifacial Solar Panel
Efficiency Increased 30%



High Efficacy Lighting
60W Replace 400W Traditional Model



Rotatable LED Module
Easy Installaton



Smart Lighting Control
IOT Remote Monitoring Analysis



Solar All in One SE Street Light

Application



SOLAR AREA LIGHTS

