

SF2144

# 46oz. Manual Bulk Foam Soap Dispenser



## FEATURES



- Dispenses approximately .4mL of foam per push
- Made from impact resistant plastic
- Long lasting foam pump
- With a translucent cover, soap is always visible
- Smooth, curved design prevents user from resting objects on unit
- ADA Compliant

## AVAILABLE COLORS

Dark Translucent



## SPECIFICATIONS

Model #	SF2144-01 (Dark Translucent)
Dimensions	5.375"W x 8.25"H x 4.50"D
Weight	1.15 lbs each
Case Pack	12 per case - 1.77' <sup>3</sup>
Capacity	46oz Foam Soap

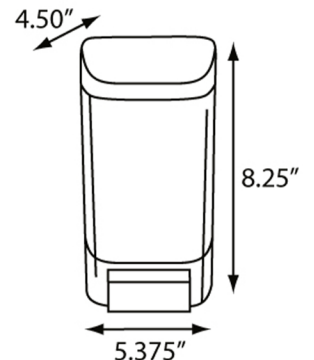

Ph: 800.558.8678  
Ph: 920.884.8698  
Fax: 920.884.8699  
info@palmerfixture.com



Palmer Fixture  
P.O. Box 10887  
Green Bay, WI 54307  
www.palmerfixture.com