

FM0148 & FM0149

Disposable Urinal Mat or Commode Mat

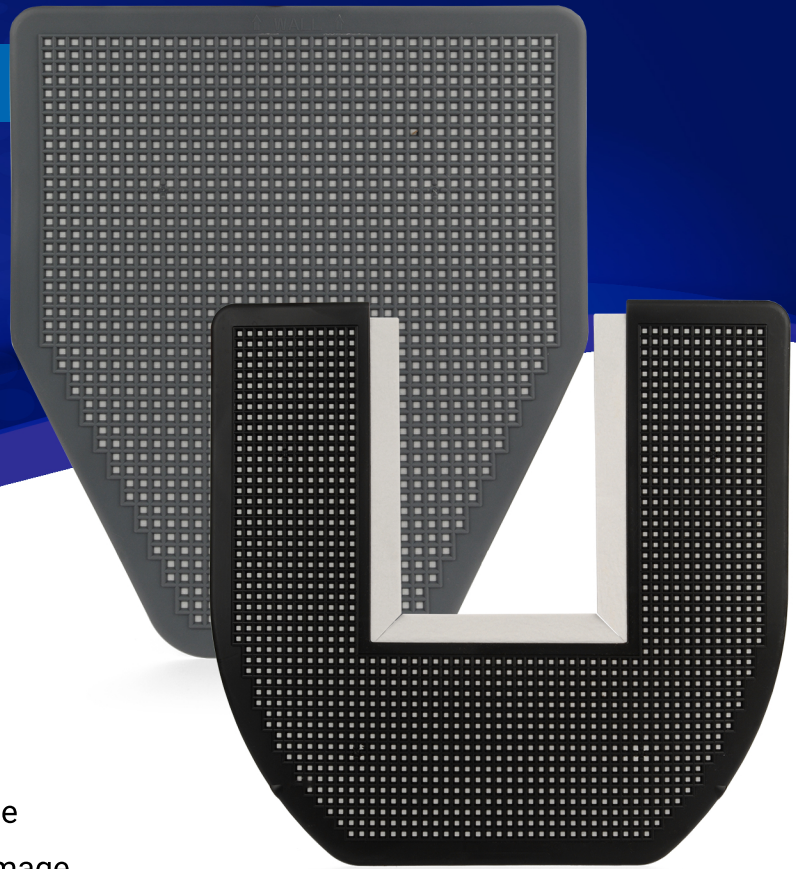

FEATURES

- Non-slip bottom provides a safe floor surface
- Protects floors from stains and uric acid damage
- Helps simplify restroom maintenance
- Helps reduce odors

SPECIFICATIONS

Model #	FM0148-21 (Grey)
Dimensions	17.75"W x 20.50"H x .03"D
Weight	.65 lbs each
Case Pack	6 per case - .33' ³

Model #	FM0149-21 (Grey)
Dimensions	23"W x 21.25"H x .03"D
Weight	.83 lbs each
Case Pack	6 per case - .44' ³

AVAILABLE COLORS

Grey

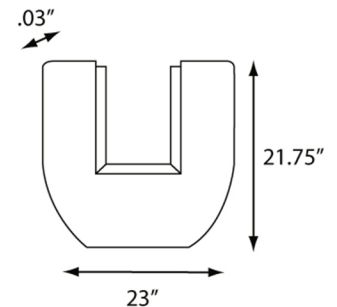
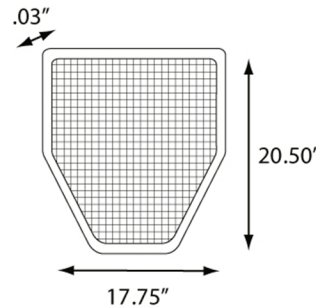

Ph: 800.558.8678
Ph: 920.884.8698
Fax: 920.884.8699
info@palmerfixture.com



Palmer Fixture
P.O. Box 10887
Green Bay, WI 54307
www.palmerfixture.com