

PROJECT:	
CATALOG #	
TYPE:	DATE:

LED VOLUMETRIC TROFFER

WITH FIELD-ADJUSTABLE LIGHT OUTPUT

DESCRIPTION

Combining top-of-the-line efficiency with a stylish, modern design, the LED Volumetric Troffer is an ideal solution for interior grid ceiling applications. Our standard model is equipped with field-adjustable light output, enabling the lumen output and wattage to be set to one of five specific levels based on the needs of the user. This feature enables not only the customization of light output, but also puts a cap on the amount of energy being used. Installation is simple and quick; this LED troffer upgrade fits seamlessly into all standard 2' x 4', 2' x 2' or 1' x 4' grid ceiling layouts.

The LED Volumetric Troffer delivers up to 125 lumens per watt (LPW) over the course of its 100,000-hour rated life. It ensures long-term energy savings over traditional fluorescent bulbs and ballasts, as well as eliminates routine maintenance, making it perfect for updating existing grid layouts or implementing in new construction. Furthermore, it's backed by an industry-leading 10-year warranty, guaranteeing peace of mind for the life of your fixture.



FEATURES

- Field-adjustable light output
- 100,000-hour rated life
- 10-year warranty
- Up to 125 LPW
- Suitable for damp locations
- 0-10V Dimming
- Compatible with Emergency Battery Backup
- DLC Premium

APPLICATIONS

- Drop/grid ceilings
- Fluorescent troffers

MARKETS

- Markets
- Schools and universities
- Offices and municipal buildings
- Healthcare facilities and hospitals

CERTIFICATIONS



SPECIFICATIONS

Life (@L70): 100,000 hours

Warranty: 10 years

PERFORMANCE

Operating temp: -4°F to 113°F (-20°C to 45°C)

CRI: 80

ELECTRICAL

Input voltage: 120-277V

Input frequency: 50/60Hz

PF: ≥.95

THD: ≤ 20%

Surge protection: ANSI C82.77 compliant

Dimming: 0-10VDC ANSI C137.x compliant

Minimum dimming: 0% of rated lumen LED drive current

Aux. Voltage: N/A

Whip/Cord: None

Sensor: N/A

INDUSTRY STANDARDS/RATINGS

IK: N/A

Location: Damp

Outdoor Rated: Yes

IC: No

UL/ETL: ETL

RoHS: Yes

DLC: 5.1 Premium

MOUNTING

Standard: T-bar grid (drop ceilings)

Wiring access: 1/2" trade size knockouts

DIMENSIONS / WEIGHT

SIZE	LENGTH	WIDTH	HEIGHT
2' x 4'	47.75"	23.75"	2.875"
2' x 2'	23.75"	23.75"	2.875"
1' x 4'	47.75"	11.9"	2.875"

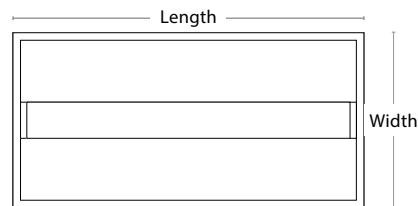

Panel (2' x 4' shown here)

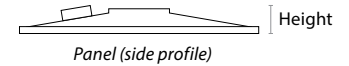

ACCESSORIES

Emergency Battery Backup
Surface Mounting Kit

Drywall Mounting Kit
Suspension Mounting Kit

PRODUCT OVERVIEW AND INSTALLATION

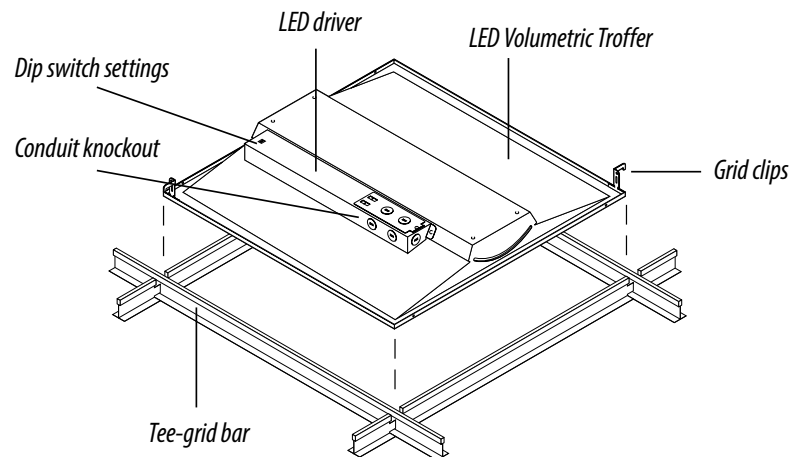
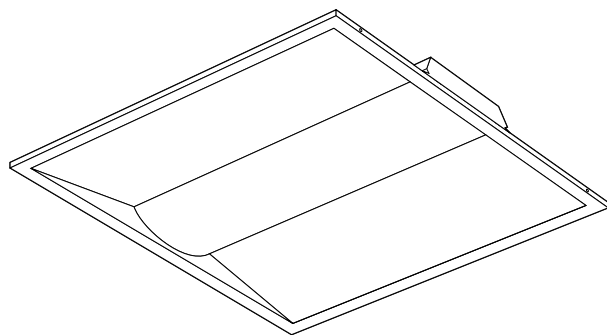

ORDERING INFORMATION

Listed below are the included wattage settings and lumens for each model number.

2' X 2'

ROOT MODEL #	DESCRIPTION		
VLT235	2X2 LED Volumetric Troffer		
EXT. MODEL #	WATTAGE	CCT	LUMENS
VLT23518	18	3500	2,250
VLT23520*	20	3500	2,500
VLT23525*	25	3500	3,125
VLT23530*	30	3500	3,750
VLT235	36	3500	4,500

ROOT MODEL #	DESCRIPTION		
VLT240	2X2 LED Volumetric Troffer		
EXT. MODEL #	WATTAGE	CCT	LUMENS
VLT24018	18	4000	2,250
VLT24020*	20	4000	2,500
VLT24025*	25	4000	3,125
VLT24030*	30	4000	3,750
VLT240	36	4000	4,500

ROOT MODEL #	DESCRIPTION		
VLT250	2X2 LED Volumetric Troffer		
EXT. MODEL #	WATTAGE	CCT	LUMENS
VLT25018	18	5000	2,250
VLT25020*	20	5000	2,500
VLT25025*	25	5000	3,125
VLT25030*	30	5000	3,750
VLT250	36	5000	4,500

2' X 4'

ROOT MODEL #	DESCRIPTION		
VLT435	2X4 LED Volumetric Troffer		
EXT. MODEL #	WATTAGE	CCT	LUMENS
VLT43525	25	3500	3,125
VLT43530*	30	3500	3,750
VLT43540*	40	3500	5,000
VLT43545*	45	3500	5,625
VLT435	50	3500	6,250

ROOT MODEL #	DESCRIPTION		
VLT440	2X4 LED Volumetric Troffer		
EXT. MODEL #	WATTAGE	CCT	LUMENS
VLT44025	25	4000	3,125
VLT44030*	30	4000	3,750
VLT44040*	40	4000	5,000
VLT44045*	45	4000	5,625
VLT440	50	4000	6,250

ROOT MODEL #	DESCRIPTION		
VLT450	2X4 LED Volumetric Troffer		
EXT. MODEL #	WATTAGE	CCT	LUMENS
VLT45025	25	5000	3,125
VLT45030*	30	5000	3,750
VLT45040*	40	5000	5,000
VLT45045*	45	5000	5,625
VLT450	50	5000	6,250

1' X 4'

ROOT MODEL #	DESCRIPTION		
VLT135	1X4 LED Volumetric Troffer		
EXT. MODEL #	WATTAGE	CCT	LUMENS
VLT13518	18	3500	2,250
VLT13520*	20	3500	2,500
VLT13525*	25	3500	3,125
VLT13530*	30	3500	3,750
VLT135	36	3500	4,500

ROOT MODEL #	DESCRIPTION		
VLT140	1X4 LED Volumetric Troffer		
EXT. MODEL #	WATTAGE	CCT	LUMENS
VLT14018	18	4000	2,250
VLT14020*	20	4000	2,500
VLT14025*	25	4000	3,125
VLT14030*	30	4000	3,750
VLT140	36	4000	4,500

ROOT MODEL #	DESCRIPTION		
VLT150	1X4 LED Volumetric Troffer		
EXT. MODEL #	WATTAGE	CCT	LUMENS
VLT15018	18	5000	2,250
VLT15020*	20	5000	2,500
VLT15025*	25	5000	3,125
VLT15030*	30	5000	3,750
VLT150	36	5000	4,500

Each extended model # is individually listed with DLC. The highest wattage is listed under the root model #.

*Model not DLC approved.

EMERGENCY BATTERY BACKUP

MODEL #	DESCRIPTION	USAGE
EB10	10W Emergency Battery Backup	Supplies battery backup to an individual fixture for up to 90 minutes. <u>Must be ordered with EBCM or EBAM indicator module.</u>
EBCM	Ceiling-mounted Indicator Module	In grid ceiling applications, this unit connects to the EB10 and is recess mounted in an adjacent panel where it displays the unit's current status of operation.
EBAM	Adhesive-mounted Indicator Module	In drywall/open ceiling applications, this unit connects to the EB10 and is mounted via adhesive, where it displays the unit's current status of operation.

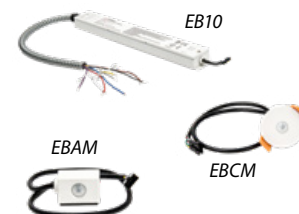

ORDERING INFORMATION

DRYWALL MOUNT KIT

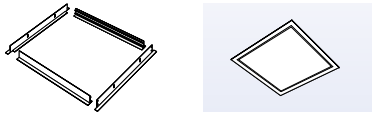

SURFACE MOUNT KIT

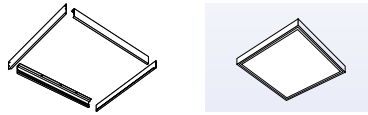

SUSPENSION MOUNT KIT

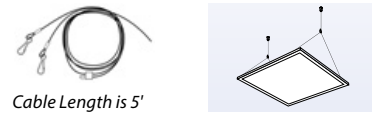

DRYWALL MOUNT KIT

MODEL #	DESCRIPTION	USAGE	OUTSIDE DIMENSIONS
FPAM224	2x4 Drywall Mount Kit	Recess mount 2x4 Panels in ceiling surfaces	47.85" x 23.94" x 2.44"
FPAM222	2x2 Drywall Mount Kit	Recess mount 2x2 Panels in ceiling surfaces	24.07" x 23.94" x 2.44"
FPAM221	1x4 Drywall Mount Kit	Recess mount 1x4 Panels in ceiling surfaces	47.85" x 11.97" x 2.44"

SURFACE MOUNT KIT

MODEL #	DESCRIPTION	USAGE	OUTSIDE DIMENSIONS
PTAM204	2x4 Surface Mount Kit	Surface mount 2x4 Panels to ceiling surfaces	47.85" x 23.94" x 3.1875"
PTAM202	2x2 Surface Mount Kit	Surface mount 2x2 Panels to ceiling surfaces	24.07" x 23.94" x 3.1875"
PTAM301	1x4 Surface Mount Kit	Surface mount 1x4 Panels to ceiling surfaces	47.85" x 11.97" x 3.1875"

SUSPENSION MOUNT KIT

MODEL #	DESCRIPTION	USAGE	WEIGHT RATING	MAX DISTANCE FROM CEILING
PTAM214	2x4 Suspension Mount Kit	Suspend 2x4 Panels from ceiling	25 lbs	4.45'
PTAM212	2X2 Suspension Mount Kit	Suspend 2x2 Panels from ceiling	25 lbs	4.45'
PTAM211	1X4 Suspension Mount Kit	Suspend 1x4 Panels from ceiling	25 lbs	4.45'