

PROJECT:	
CATALOG #	
TYPE:	DATE:

LED LINEAR HIGH BAY

SENSOR CAPABLE with ONBOARD PLUG-IN PORT (Standard). CHOICE OF SENSORS (Microwave, PIR, LiteSmart Bluetooth) OPTIONAL.

DESCRIPTION

The LED Linear High Bay goes above and beyond the standards, delivering top-of-the-line efficiency and versatility that results in a truly optimized approach to each application.

This high bay is available in a range of wattages and features selectable CCT functionality, allowing the installer to choose between 4000K or 5000K. The options don't end there; each unit can accommodate a pluggable sensor that enables increased energy saving features such as occupancy sensing and daylight harvesting, both of which can be adjusted via remote control. Our Smart Sensor enables the same energy saving features, but can be setup and managed on a group level via the LiteSmart mobile app.

The fixture also offers versatility in installation. It comes standard with suspension cables and a 10' cord, making it an easy upgrade from linear fluorescent fixtures. For pendant or surface mounting, a single mounting kit covers both options.



FEATURES

- Pluggable sensor (enabling occupancy sensing or daylight harvesting)
- Compatibility with LiteSmart mobile app
- Selectable CCT (4000K or 5000K)
- UL rated for damp locations
- DLC 5.1 Premium (160 LPW)
- 100,000-hour rated life
- 10-year warranty
- Polycarbonate, frosted lens
- 120-277V or 277-480V
- 10' cord
- 0-10V dimming
- Emergency battery backup available



APPLICATIONS

- Warehouse & storage
- Industrial facilities
- Sports facilities & gyms
- Manufacturing facilities
- Retail centers

MOUNTING

- Suspension
- Pendant
- Surface

CERTIFICATIONS



SPECIFICATIONS

Life (@L70): 50,000 hours | 100,000 hours

Warranty: 5 years | 10 years

PERFORMANCE

Operating temp:

-4°F to 122°F (-20°C to 50°C) = 50,000 hours | 5 Year

-4°F to 113°F (-20°C to 45°C) = 100,000 hours | 10 Year

Efficacy (LPW): 160 LPW

CRI: 80

ELECTRICAL

Input voltage: 120-277V or 277-480V

Input frequency: 50/60Hz

PF: ≥.9

THD: <20

Surge protection: 2KV

Dimming: 0-10VDC ANSI C137.x compliant

Minimum dimming: 0% of rated lumen LED drive current

Aux. Power Tap: N/A

Driver CL: Class 1

Whip/Cord: 10' cord

Sensor: Plug-in PIR, Bluetooth or microwave sensor

OPTICAL

Beam: 110°

Lens: Polycarbonate Frosted

UGR: N/A

PHYSICAL

Finish: Brushed Aluminum

Color: Silver

Housing: Extruded Aluminum

INDUSTRY STANDARDS/RATINGS

IP: 50

IK: N/A

Location: Damp

IC: N/A

UL: Yes

ETL: No

FCC: Yes

RoHS: Yes

DLC: 5.1 Premium

DIMENSIONS / WEIGHT

ORDER#	WATTAGE	WIDTH	LENGTH	HEIGHT
LHB112	112W	7.2"	23"	4.4"
LHB148	148W	7.2"	27"	4.4"
LHB248	248W	7.2"	39"	4.4"
LHB148HV	148W	7.2"	27"	4.4"
LHB248HV	248W	7.2"	39"	4.4"

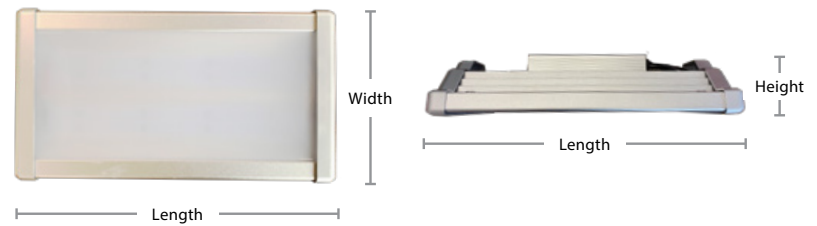

PRODUCT OVERVIEW & INSTALLATION

SUSPENDED FROM BEAM

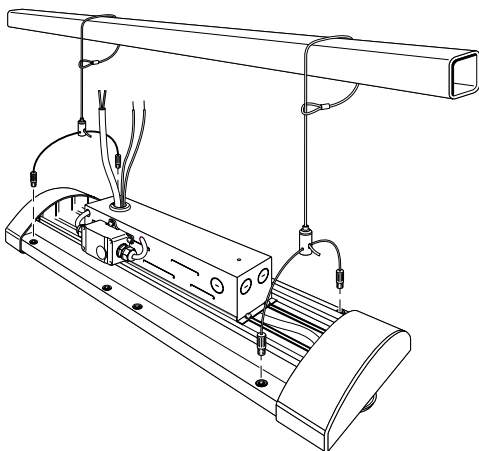

SUSPENDED FROM ANCHORED HOOKS

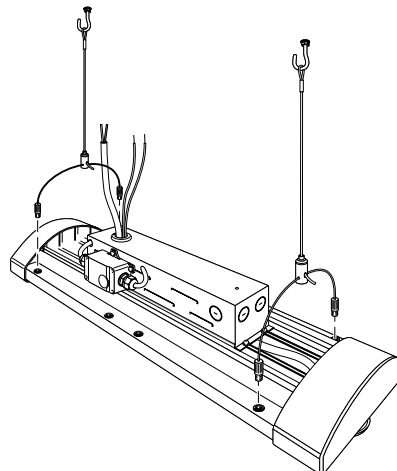

PENDANT/SURFACE MOUNTING KIT

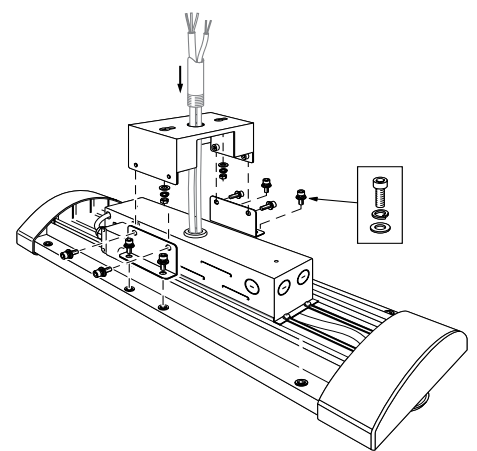

Suspension cables are included with the standard units. The Pendant/surface mounting kit must be ordered separately.

Litetrionics, Inc. | 6969 W. 73rd St. Bedford Park, IL 60638 | Tel: 800-860-3392 | customerservice@litetrionics.com

www.Litetrionics.com

ORDERING INFORMATION

Listed below are the included wattage settings and lumens for each model number.

LHB112



LHB148



LHB248



ORDERING CODE	DESCRIPTION	WATTS	VOLTS	CCT (K)	LUMENS
LHB112	112W Linear High Bay with Selectable CCT	112	120-277	4000K 5000K	17,920
LHB148	148W Linear High Bay with Selectable CCT	148	120-277	4000K 5000K	23,680
LHB248	248W Linear High Bay with Selectable CCT	248	120-277	4000K 5000K	39,680
LHB148HV	148W Linear High Bay High Voltage with Selectable CCT	148	277-480	4000K 5000K	23,680
LHB248HV	248W Linear High Bay High Voltage with Selectable CCT	248	277-480	4000K 5000K	39,680

ACCESSORIES



ORDERING CODE	DESCRIPTION	USAGE
SC005	Plug-in PIR Sensor	Enable occupancy sensing and daylight harvesting on pluggable fixtures
SC006	Plug-in Microwave Sensor	Enable occupancy sensing and daylight harvesting on pluggable fixtures.
SCR053	Remote Control	Used (with SC005 and SC006 sensor) to adjust settings after installation
SC008	Plug-in Bluetooth PIR Sensor with IR	This sensor enables wireless control of fixtures, or groups of fixtures, through the LiteSmart mobile app.
BCS02	Solar Bluetooth Control Switch	Equipped with a built-in photocell, this switch utilizes available light for power, conserving and extending the overall battery life.
BCS03	Bluetooth button battery powered wall switch	Used to control functionality of the fixture; on/off, dimming, daylight harvesting and scene selection. Dimensions: 1-1/4" width x 2 5/8" height x 1/2" depth.
BCS05	Bluetooth 7 Button AC Powered Wall Switch 120-277V	AC powered wall switch used to control functionality of the fixture; on/off, dimming and scene selection.
LHBAM22	Pendant & Surface Mount Kit	Used to pendant mount or surface mount the LED Linear High Bay
EB20	20W Emergency Battery Backup	Supplies 90 minutes of battery backup to the fixture in times of a power outage. <ul style="list-style-type: none"> This unit is compatible with fixtures using >81W and <180W. For LHB248 and LHB248HV, specify EB40. This unit is not currently compatible with sensor usage. The unit must be orderd with indicator module EBAM and Test Remote TR01.
EBAM	Adhesive-Mounted Indicator Module	This Adhesive-Mounted Indicator Module (EBAM) must be used with one of Litetronics' emergency battery backup products (EB10, EB10N or EB20) to provide a visual confirmation of the operational status of the EBB unit. This module is typically used in open ceiling or drywall ceiling applications where the module is applied to the side of the fixture, mounting kit, or a nearby structural element.
TR01	Test Remote Control	Used for testing and demonstrating the functionality of EB20 emergency battery backup integrated products. <ul style="list-style-type: none"> Only one remote required per area, building or site as necessary.
EB40	40W Emergency Battery Backup	Supplies 90 minutes of battery backup to the fixture in times of a power outage. <ul style="list-style-type: none"> This unit is compatible with fixtures using >1W and <300W. This unit is not currently compatible with sensor usage. EBAM and TR01 not required. Indicator and remote included.

Note: Switches don't have CCT selectable capability.

WIRELESS CONTROL WITH PLUGGABLE SENSORS

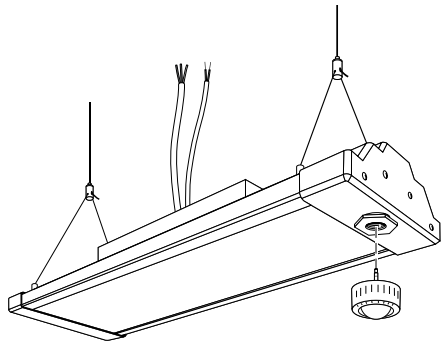

The standard PIR sensor uses a remote control for easy setup and control of individual fixtures.



The smart PIR sensor uses the LiteSmart mobile app for group setup and management.



LITESMART



LiteSmart is a mobile app that enables total management of lighting systems at the touch of your fingers. Within the app, all functionality can be set up and controlled; on/off, dimming, grouping, scene creation and time scheduling. Adjustments can also be made to the occupancy sensor and daylight harvesting settings, then implemented across an entire group in seconds.

- Total control over your lighting system
- Quick and easy changes that can be implemented in seconds across a group of fixtures
- Further energy reduction via occupancy sensing, daylight harvesting and max wattage control
- Ability to create custom scenes based on specific needs, such as presentations
- Time scheduling that sets hours of operation per day



*Set up and manage your space with LiteSmart.
Use the remote switch for everyday control.*



WIRELESS SWITCH

Part #BCS02, BCS03 or BCS05

The bluetooth control switch comes in handy for the daily occupants of a space. This switch, which can be wall mounted, enables quick adjustments to be made to a specific group of fixtures. Features include on/off, dimming, daylight harvesting and scene selection. The switch must be set up through the LiteSmart mobile app, but can then function on it's own within any space.

BENEFITS

- Control over key functions for a specific group of lights
- Adjustments are quick and easy, and create an optimized space for a variety of needs
- Further reduce energy via daylight harvesting function, or disable daylight harvesting for full brightness
- Ability to choose between custom scenes based on specific needs within the space

SWITCH CAPABILITIES

- Enable/disable auto daylight harvesting
- Brighten/dim a group or turn on/off the entire group of fixtures
- Program up to 3 scenes per switch