

## LED High Ceiling Panel Installation Instructions

Selectable Output Series | 2' x 2', & 2' x 4'

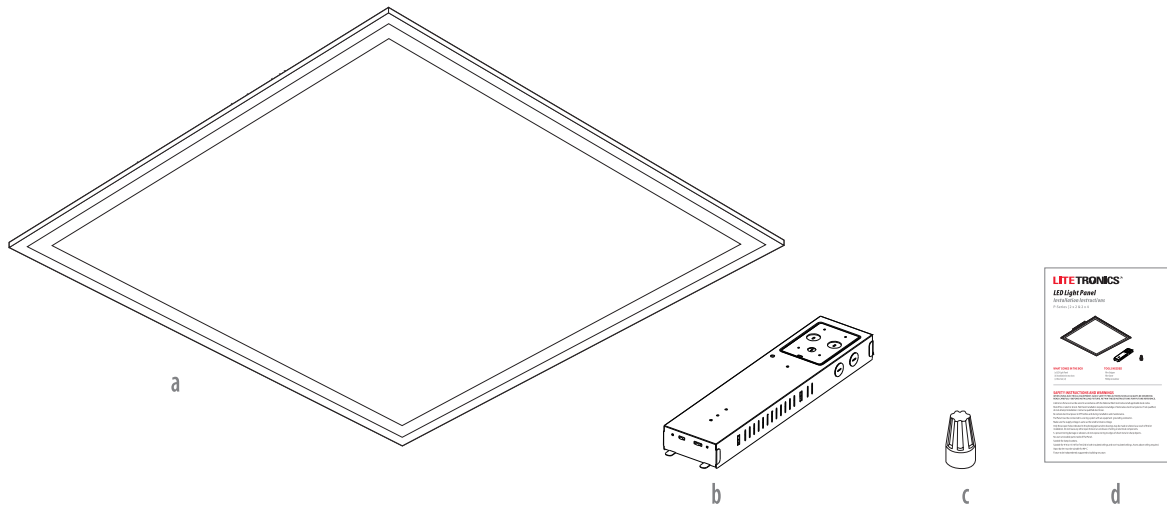

### WHAT COMES IN THE BOX

- (a) LED High Ceiling Panel
- (b) Driver box
- (c) Wire Nut (x5)
- (d) Installation Instructions
- (e) Screw (x2)

### TOOLS NEEDED

- Wire Stripper
- Wire Cutter
- Phillips Screwdriver

## SAFETY INSTRUCTIONS AND WARNINGS

WHEN USING ELECTRICAL EQUIPMENT, BASIC SAFETY PRECAUTIONS SHOULD ALWAYS BE OBSERVED. READ CAREFULLY BEFORE INSTALLING FIXTURE. RETAIN THESE INSTRUCTIONS FOR FUTURE REFERENCE.

Litetronics fixtures must be wired in accordance with the National Electrical Code and all applicable local codes.

Risk of fire or electric shock. High Ceiling Panel installation requires knowledge of luminaires electrical systems. If not qualified, do not attempt installation. Contact a qualified electrician.

Be certain electrical power is OFF before and during installation and maintenance.

High Ceiling Panel must be connected to a wiring system with an equipment – grounding conductor.

Make sure the supply voltage is the same as the rated luminaire voltage.

Only the open holes indicated in the photographs and/or drawings may be made or altered as a result of this kit installation. Do not leave any other open holes in an enclosure of wiring or electrical components.

To prevent wiring damage or abrasion, do not expose wiring to edges of sheet metal or sharp objects.

No user serviceable parts inside of High Ceiling Panel.

Suitable for damp locations.

Suitable for 9/16" or 15/16" Flat Tee Grid in both insulated ceilings and non-insulated ceilings. Access above ceiling required.

Vapor barrier must be suitable for 90° C.

Fixture to be independently supported to building structure.

# INSTALLATION PROCEDURE

## READ ALL INSTRUCTIONS BEFORE BEGINNING INSTALLATION

1. Connect the driver to panel with quick plug connector on desk or floor.
2. Push the driver into the slot position and tighten the screws.
3. Turn off power at the electrical panel.
4. Remove the ceiling tile or existing fixture from the grid ceiling space.
5. Before installing, locate the grid clips on your panel; bend them up and out so they can rest on top of the grid.
6. Unscrew and remove the driver cover to access the input ports, ground and dimming wires.
7. Locate the adjustable wattage slide switch on the side of the driver and set to the desired wattage. See slide switch settings below.
8. Tilt and raise the panel up into the empty grid space, then lower until the grid clips catch on the tee-grid bar. Attach the panel to the building with support wires (not included) using the hole in the grid clip.
9. Remove one conduit knock-out from the driver, then run branch power wire from the conduit to the driver.
10. Make wiring connections using wire nuts.
  - a. Connect the live power (black) line to ACL(Black)
  - b. Connect the neutral(white) line to ACN(White)
  - c. Connect the green ground line to GND(Green)
  - d. If 0 -10V dimming is required, connect incoming dimming lines to the DIM+ (Purple) and DIM- (Gray/Pink) wires. Follow dimmer manufacturers instruction
11. Close the driver cover and secure it with the screw.

## WATTAGE SLIDE SWITCH SETTINGS

2' X 2'

WATTAGE	LUMENS
150	25500
170	28900
215	36550

2' X 4'

WATTAGE	LUMENS
260	44200
290	49300
325	55250

## CCT SLIDE SWITCH SETTINGS

5000K	4000K
-------	-------

# INSTALLATION PROCEDURE

## DRIVER BOX ASSEMBLING

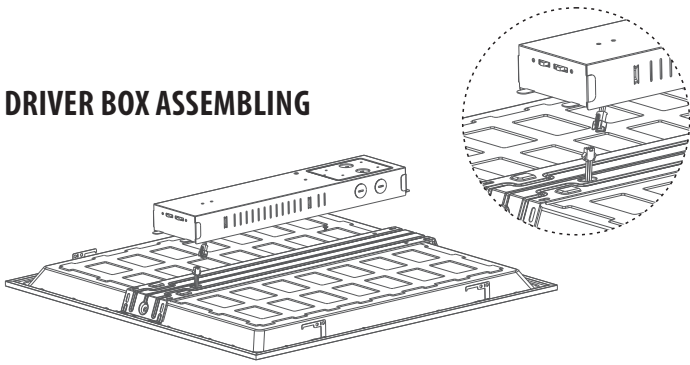

**1.** Connect the driver to the panel with quick plug connector.

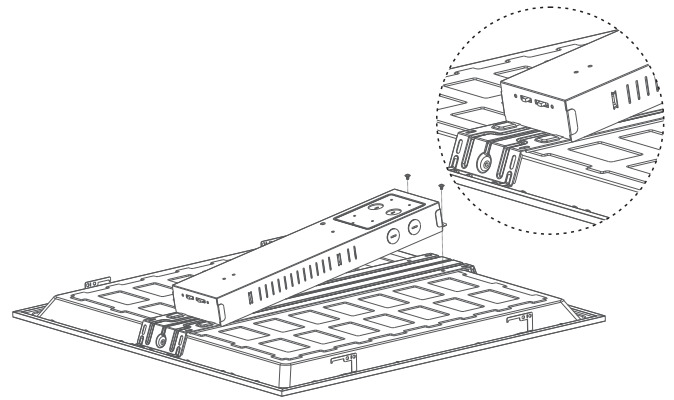

**2.** Push the driver into the slot position.

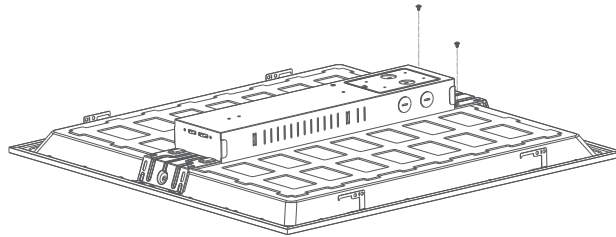

**3.** Lock the driver box on the bracket by screws.

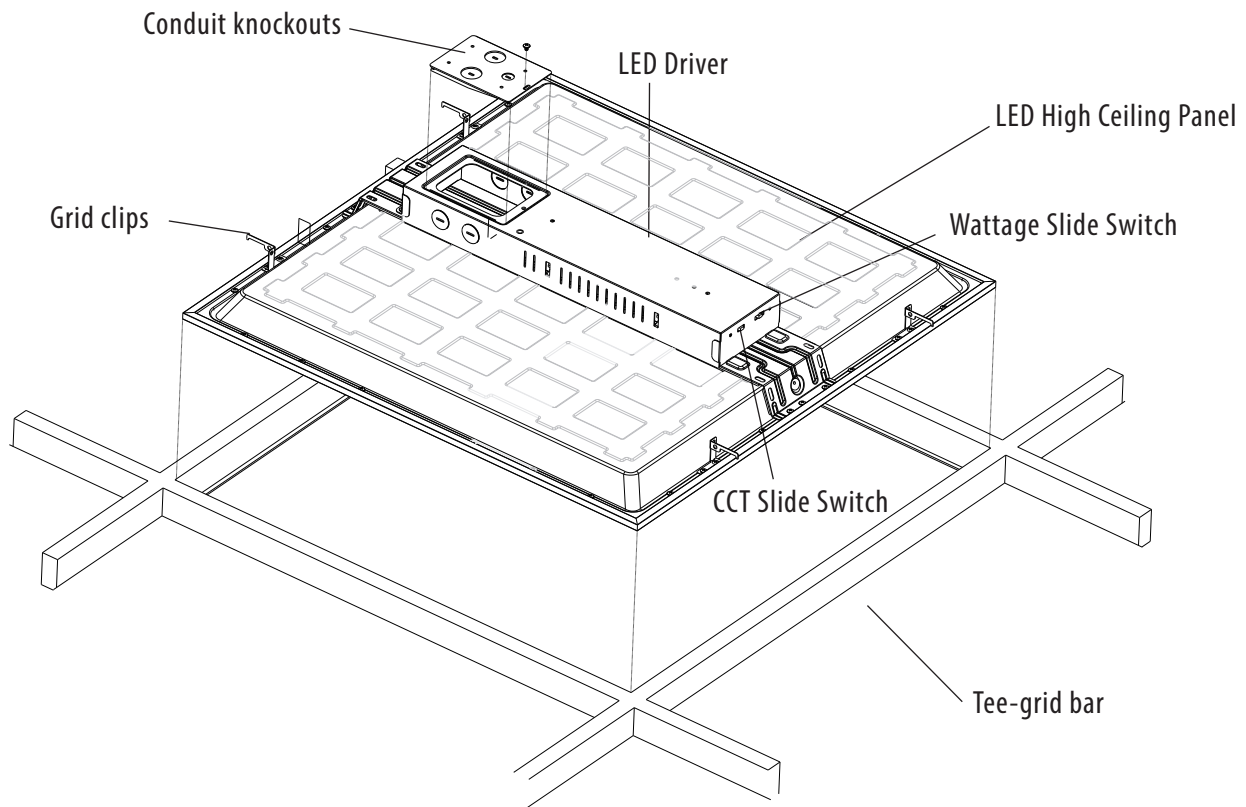

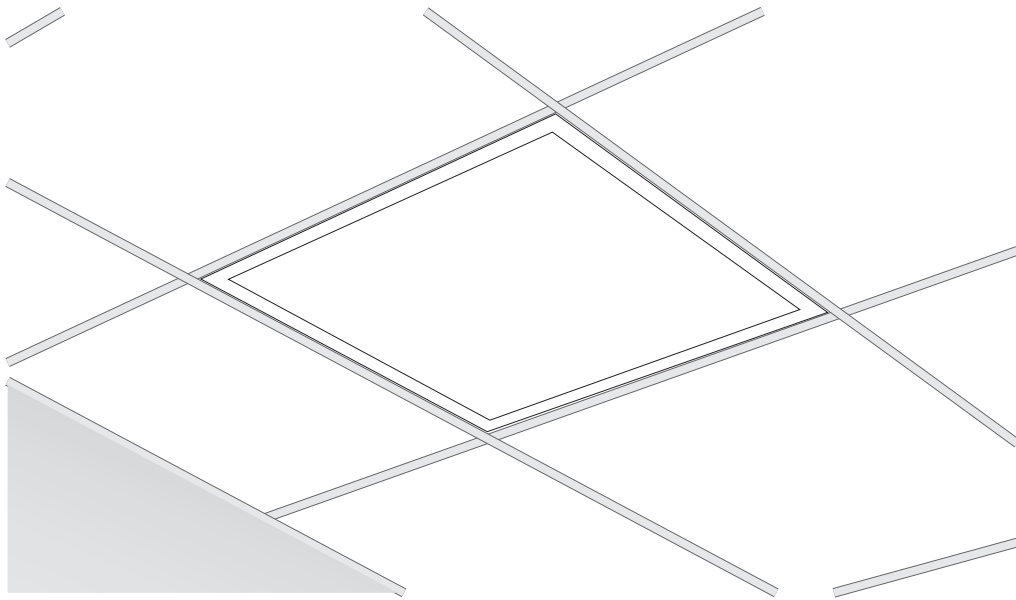

Thank you for choosing

**LITETRONICS®**

6969 W. 73rd Street  
Bedford Park, IL 60638

[WWW.LITETRONICS.COM](http://WWW.LITETRONICS.COM)

[CustomerService@Litetronics.com](mailto:CustomerService@Litetronics.com) or 1-800-860-3392



The information and product specifications contained in these instructions are based upon data believed to be accurate at the time of printing. This information is subject to change without notice and without incurring liability. If you have questions regarding specific product details, please contact us at 800-860-3392 or via email at [customerservice@litetronics.com](mailto:customerservice@litetronics.com).

To check for an updated version of these instructions, please visit [www.litetronics.com](http://www.litetronics.com).

6/9/22