

Incandescent Thermoplastic Emergency Unit

Project:	
Catalog#:	
Approved by:	



Mounting

- Universal knockout pattern on back plate for wall mount. Snaps into place making internal electrical connections.
- Knockout for conduit applications.



Housing

- Injection-molded, engineering grade, 5VA flame retardant, high-impact resistant, thermoplastic in white or black finish.

Illumination

- Two fully adjustable 5.4 watt glare-free lamp heads.
- Smooth thermoplastic reflector and plastic lens for optimal light distribution.

Warranty & Listings

- Five year warranty on all electronics and housing. Batteries prorated for two years.
- Meets UL924, NFPA 101 Life Safety Code, NEC, OSHA, Local and State Codes.
- Meets CSA C22.2 No. 141-02 Requirements for unit equipment.
- UL listed for damp locations (20°C – 50°C).

Electrical

- Dual 120/277 voltage.
- Charge rate/power "ON" LED indicator light and push-to-test switch for mandated code compliance testing.
- LVD (low voltage disconnect) prevents battery from deep discharge.
- 6V maintenance-free, rechargeable sealed lead acid battery.
- Internal solid-state transfer switch automatically connects the internal battery to lamp heads for minimum 90-minute emergency illumination.
- Fully automatic solid-state, two rate charger initiates battery charging to recharge a discharged battery in 24 hours.

Dimensions

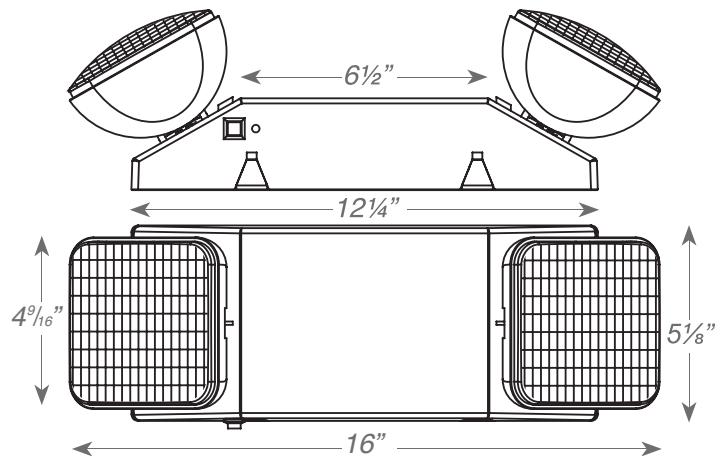

Ordering Information	
Model Number	Color
HL0202SW	White